

A novel, high-performance, and versatile instrument for monitoring various rain parameters has been developed. It consists of three flexible, multipolarization radar systems with extremely precise amplitude and phase calibration. The three radars operate at 13.6, 25, and 37 GHz and are completely software controlled.

The primary objective for this development is to provide precise, versatile equipment for monitoring rain parameters. The multifrequency measurement of amplitude and phase of the scattered signals provide rain drop size distribution. The polarimetric measurements allow drop shape estimation. Doppler measurements allow inferences to be drawn regarding the wind

speed and distinguish between snow and rain. The radars provide area coverage of 1 km² and the range cell resolution can be increased by various waveforms.

The radars can be operated in various modes. The software control enables all the radar parameters to be configured and re-configured, allowing extreme flexibility and versatility. The user interface is provided through the well known Windows® operating system, enabling familiarity and ease of use.

Each radar unit has two receiving and two transmitting channels with different (vertical or horizontal) polarizations. The transmitters can be alternated at each IPP or after any selected number of IPPs. The receiver channels (V and H) always operate for each IPP.

Keeping the Tx fixed (say at V) provides both VV and VH measurements at the two receiver outputs. Tx alternating between V and H, one gets VV, VH, HV, and HH observations at the same time.

The system has a calibration mode, where a portion of the transmitted signal is fed directly into the receiver chain, ensuring the overall system gain (Tx and Rx combination) and phase stability.

The radar parameters (Inter Pulse Periods (IPPs), Tx pulses, waveforms, sampling region, sampling rate, etc.) can be changed by the user using a menu driven interface. The radar can be operated with various types of waveforms (Pulse, FM, Phase Coded, etc.). Each IPP can be selectively defined. A sequence of IPPs are grouped as frames. A frame may consist of any number of IPPs of various types. The data for each IPP are separated in different buffers.



MICROWAVE RAIN GAUGE

(DASR-HD-003-05)

POLARIMETRY

- Each radar has:
 - › Two transmitters (V and H)
 - › Two receivers (V and H)

Two Receivers always work together. Transmitters can be alternated.

- This provides:
 - › VV, VH - for V transmission
 - › HV, HH - for H transmission

Complete polarimetric measurements are available.

CALIBRATION

The radars provide high accuracies in both amplitude and phase. These high accuracies are ensured through the use of novel calibration channels where a small (precisely calibrated) fraction of the transmitted signals are fed into the receiving system ensuring calibration of the Tx-Rx chain.

A portion of the transmitter signal is fed into the receiver channels.

CLUTTER

Data buffers are maintained for clutter and calibration measurements. These can be used in real-time for deriving precise measurements (clutter subtracting, calibration gain adjustments).

USER INTERFACE

The user interface is provided through the familiar Windows ® OS. The basic element is IPP.

- All the parameters within the IPP can be individually selected
- Various combinations of IPPs can be defined within a frame.
- Data is transferred after each frame.
- Multiple frames can be defined.

Three identical systems covering 13.6, 25, and 37 GHz have been developed and are available.

These radars are capable of:

1. Measuring attenuation phase and polarization with high precision and at multiple frequencies
2. Use in monostatic and bistatic modes
3. Use as radar for measuring backscatter
4. Providing line-average and area averaged measurements
5. Reconfiguration and portability
6. Optimization for large-scale production

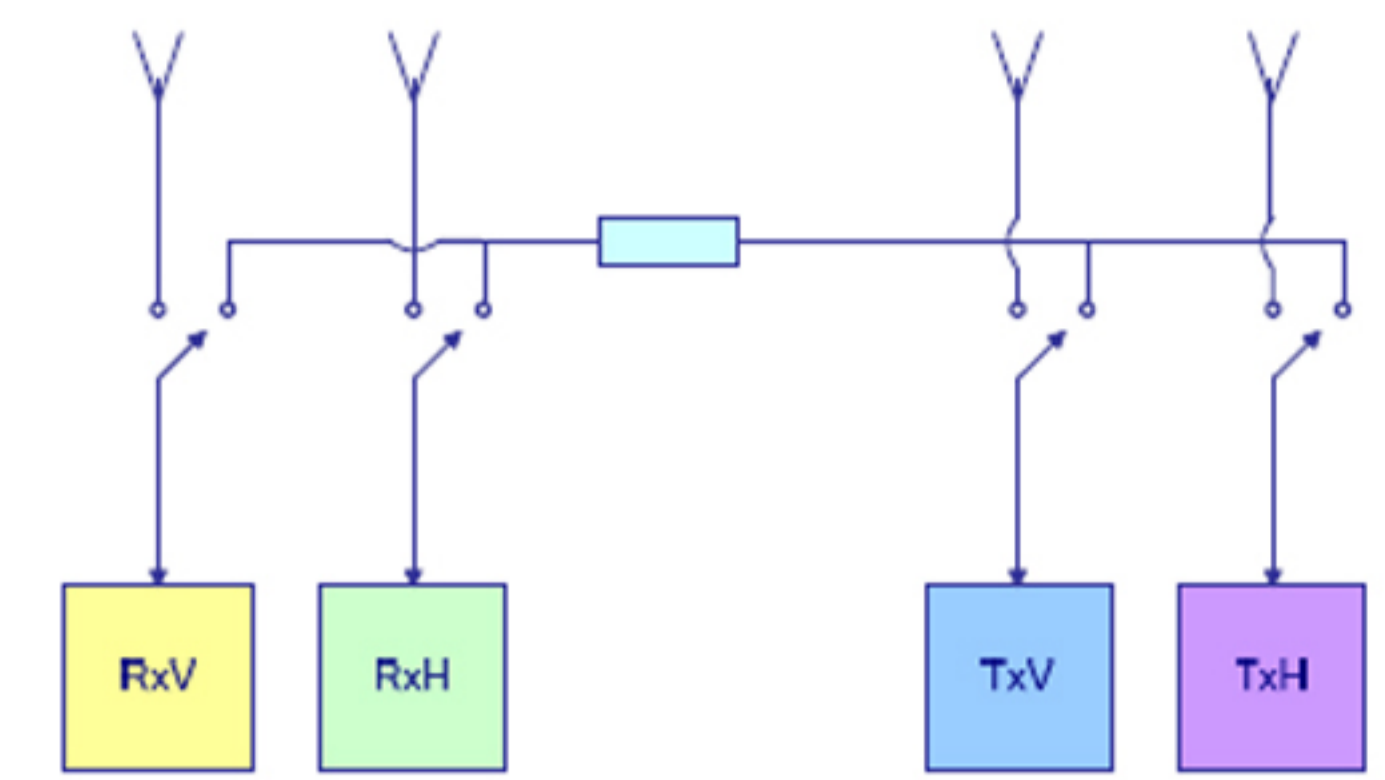

SPECIAL FEATURES

- Extremely stable and accurate
- Large Dynamic Range
- Digital Software Receiver - Flexible
- All Polarization combinations

FEATURES

- Three independent channels at 13.6, 25, and 37 GHz
- Both Forward and Backscatter configuration
- Dual Polarization
- Coherent Frequencies
- Extremely precise calibrated outputs
- Programmable Software Radar, Digital Processing Variable power, Digital processing, Flexible, Portable system
- Variable duty cycle, variable range and resolution
- Flexible, Portable system can be deployed in ground, can be flown in an aircraft, can be adapted for space - borne applications

APPLICATION

1. Area-averaged rain measuring instrument provides accurate measure of rainfall
2. Multifrequency and multiparameter (amplitude-phase-polarization) active system provides information about rain-rate, drop-size distribution, and velocity distribution
3. This information may be used to retrieve snow-fall, water content, melting snow, and related data
4. **Application includes:**
 - (a) Validation and Supplementation of Rain Radars
 - (b) Area-average measurements for global environment
 - (c) Meteorological application - combination with NEXRAD Airport monitoring
 - (d) Hydrological application - Water sheds, River runoff
 - (e) Hydroelectric and Electric utilities - Snow fall on transmission lines, prediction of rain/snow